

OVERVIEW

2025



cimtas | steel



cimtas | pipe



cimtas | shipyard



cimtas | ningbo



cimtas | machining



400,000 t
CAPACITY

5,000
EMPLOYEES

ZERO
INCIDENT POLICY

ÇİMTAŞ GROUP, a subsidiary of ENKA, having with an aggregated annual capacity of 400,000 tons, provides engineering, procurement, fabrication, machining, modularization, erection and installation services to the leading customers of construction, power, oil, gas and chemicals industries.

COMPANY STRUCTURE

ENKA



cimtas | steel



cimtas | pipe

cimtas | shipyard

cimtas | ningbo

cimtas | machining

More than **580** Projects in **57** Countries
More than **63 Billion USD** Historical Contract Value

54th @ ENR Top 250 International Contractors List - 2024
More than **20,000** Employees

ENKA



OIL, GAS & PETROCHEMICALS



POWER PLANTS



INFRASTRUCTURE



BUILDING WORKS



80,000 t CAPACITY **ZERO** INCIDENT POLICY

 Gemlik / Türkiye
160,000 m²

ÇİMTAŞ STEEL, being the flagship company of ÇİMTAŞ GROUP; provides engineering, welded fabrication, modularization and installation services to the leading customers of construction, power, oil, gas, chemicals and offshore industries.

cimtas | pipe



3 Million DIA"
SPOOL FABRICATION
CAPACITY

100,000 t
LSAW PIPE
CAPACITY

6,000 t
FITTINGS
CAPACITY

Gemlik FTZ / Türkiye
120,000 m²

CİMTAS PIPE is a market-leading company providing engineering, procurement, manufacturing of LSAW pipes and fittings, fabrication of pipe spools for power, oil, gas and nuclear industry with the best in class vision.

cimtas | shipyard



80,000 t
FABRICATION
CAPACITY

70,000 t
ASSEMBLY
CAPACITY

Gölcük FTZ / Türkiye
270,000 m²

ÇİMTAŞ SHIPYARD fabricates structural steel, steel wind towers, offshore & subsea structures, modules and sea vessels at its facility having vast assembly yards and a self-quay for direct sea transportation.



1.5 Million DIA"
SPOOL FABRICATION
CAPACITY

6,000 t
SKID & MODULES
ASSEMBLY CAPACITY

Ningbo FTZ / China
56,000 m²

CIMTAS NINGBO provides process & OEM piping, skid-mounted process assemblies and modularization solutions to power, oil & gas and petrochemical industries.



7 NADCAP
5 MERIT
200,000 HOURS
5 AXIS MACHINING

 Gemlik FTZ / Türkiye
13,000 m²

ÇİMTAŞ MACHINING is the most technologically advanced member of ÇİMTAŞ GROUP; providing complex gas turbine parts & modules to the leading OEMs of both the power and aerospace industries.



STRUCTURAL
STEEL



PRESSURIZED
EQUIPMENT



STEEL
WIND TOWERS



INSTALLATION



OFFSHORE
STRUCTURES



MODULARIZATION



SHIPBUILDING &
POWERSHIPS



SPOOLS



FITTINGS



LSAW PIPES



GAS TURBINE
COMPONENTS



SATELLITE
COMPONENTS



HIGH RISES



STEEL BRIDGES



POWER, OIL & GAS PLANTS



INDUSTRIAL PLANTS



AIRPORTS



STADIUMS



TCO FUTURE GROWTH PROJECT

Kazakhstan



ICA FLUOR PROJECT

Mexico



ANGOLA LNG

Angola



PEMEX PRESSURE VESSELS

Mexico



8 m DIAMETER



300 t SECTION WEIGHT



35 m LENGTH



25 COUNTRIES



İZMİR-GEBZE-ADAPAZARI CCPP 3,850 MW

Türkiye



WALSUM COAL FIRED POWER PLANT 800 MW

Germany



RIJNMOND CCPP 770 MW

The Netherlands



SECOND GENERATION PROJECT 25 Million t

Kazakhstan



SAKARYA GAS FIELD DEVELOPMENT PROJECT



Türkiye



SAKARYA GAS FIELD DEVELOPMENT PROJECT



Türkiye



KUZEY MARMARA UNDERGROUND GAS STORAGE EXPANSION PROJECT

Türkiye



STINGER SECTION PROJECT

The Netherlands





WEST QURNA PROJECT



Iraq SECOND GENERATION PROJECT

Kazakhstan



PETROBRAZI PLANT CCR

Romania



POLY BED HYDROGEN PURIFICATION SKID

Russia



KPS6 POWERSHIP

Türkiye



KPS9 POWERSHIP

Türkiye



GMK-1 DYNAMIC POSITIONING SERVICE VESSEL

Türkiye



SOLEY-4

Türkiye

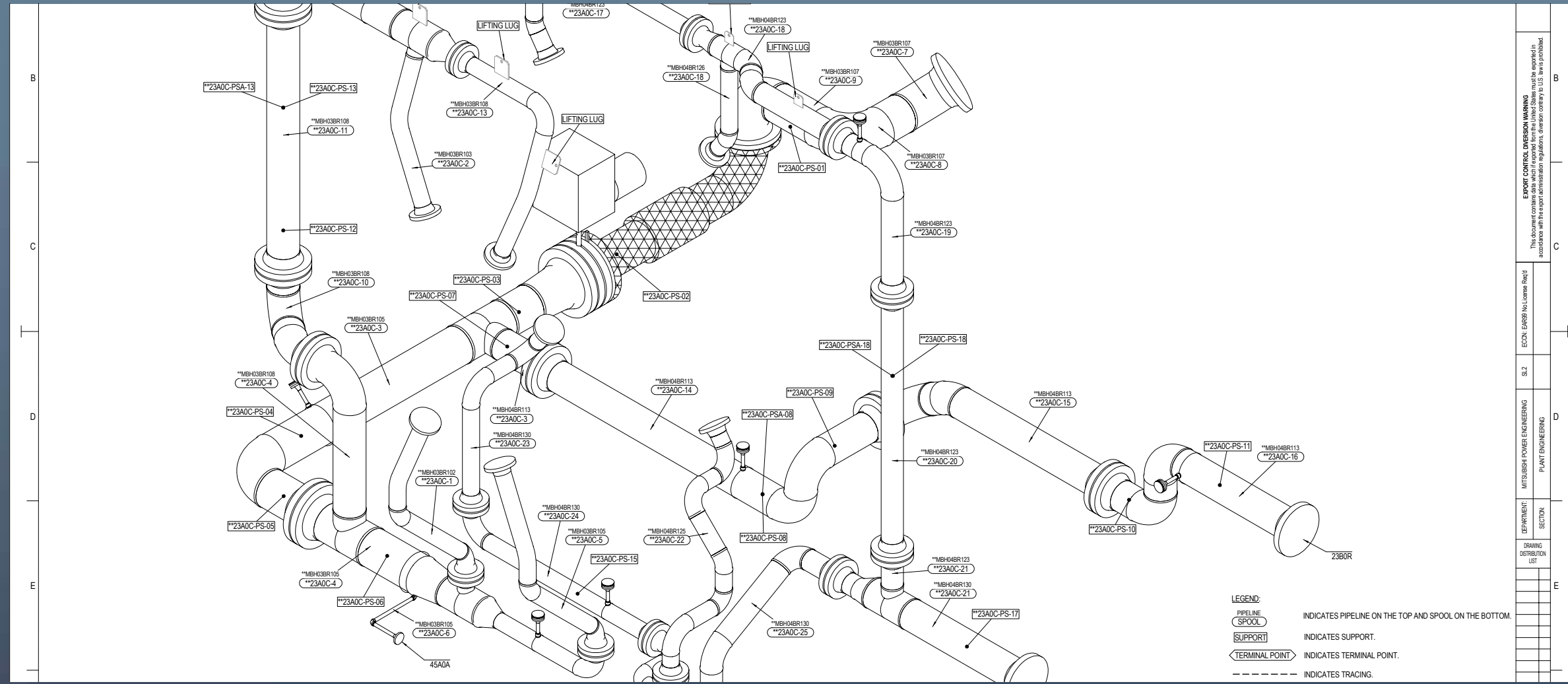

ENGINEERING



FABRICATION



PACKAGING



TRANSPORTATION

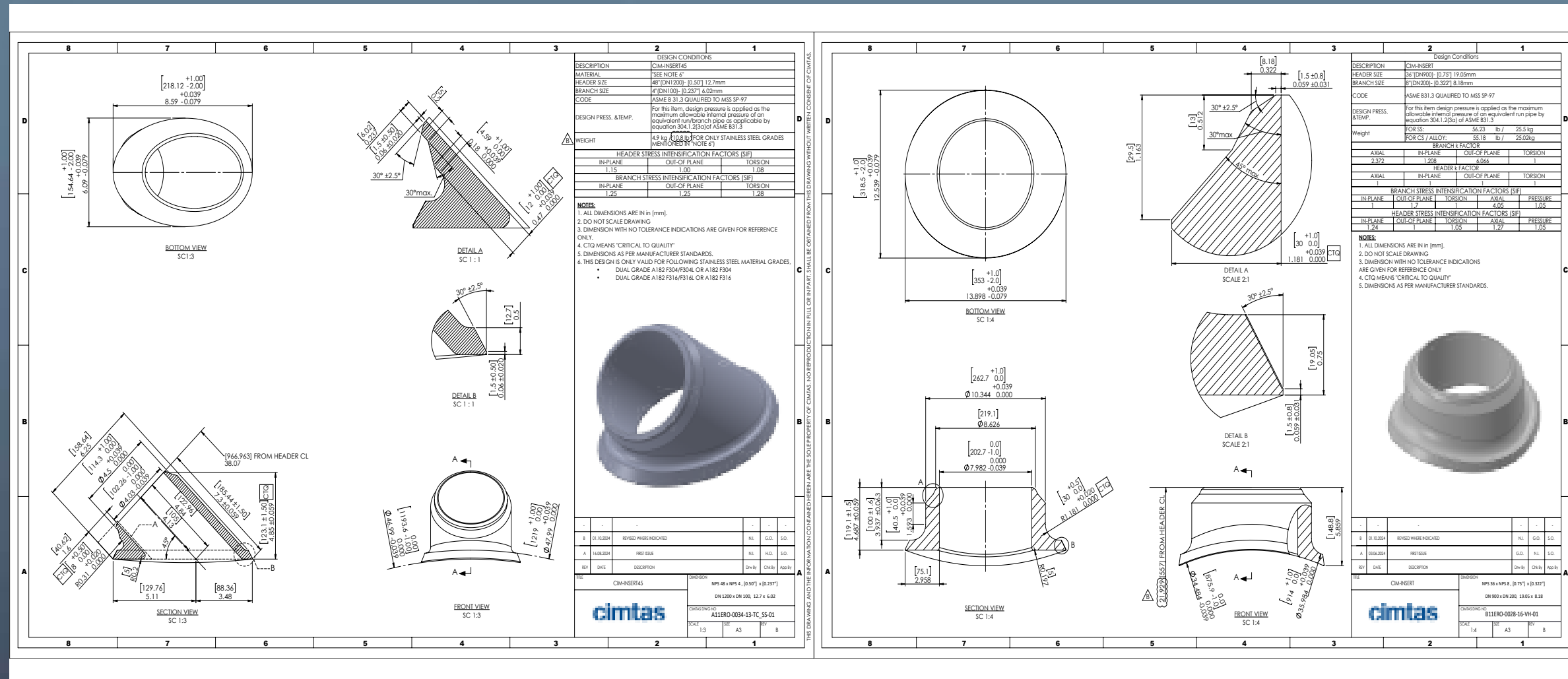

ENGINEERING

HOT FORMING



INDUCTION BENDING



TEES

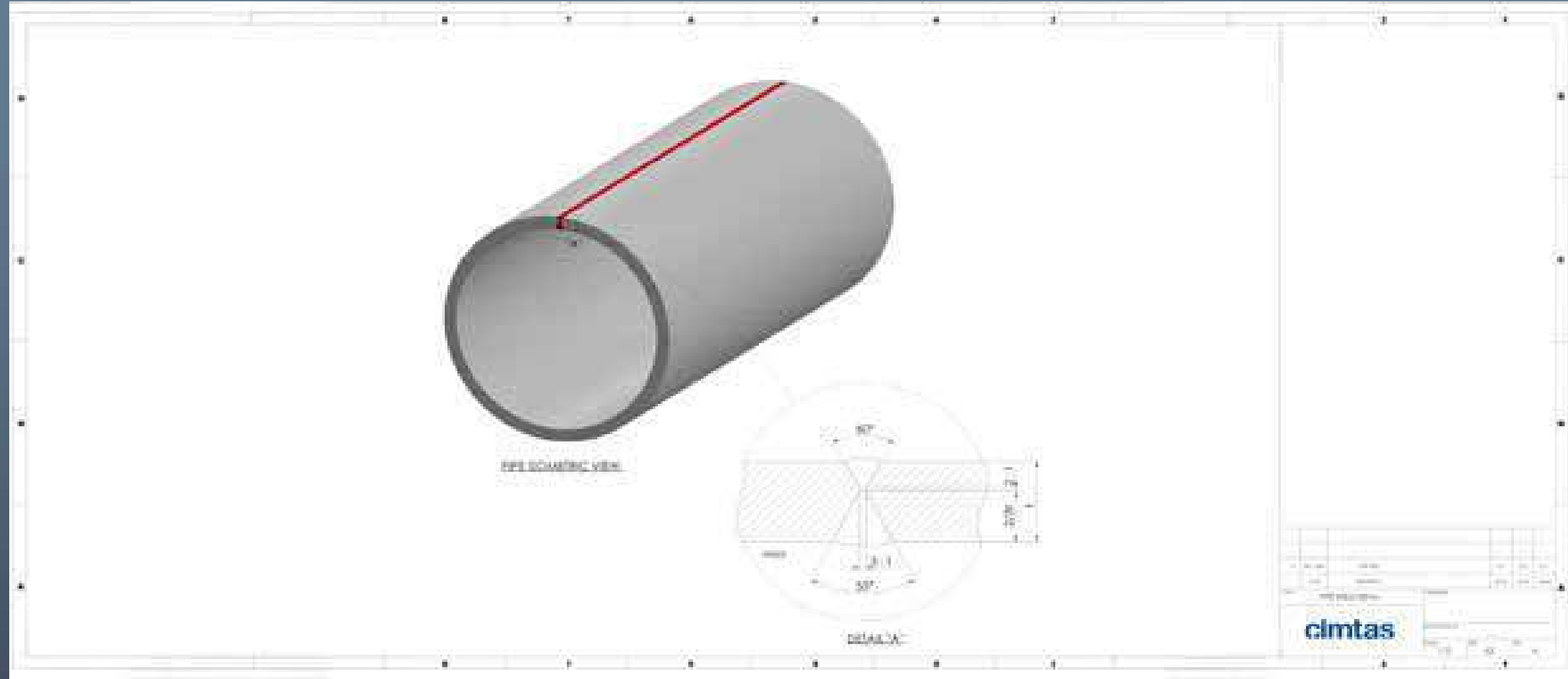

ENGINEERING



FABRICATION



JCO FORMING



HEAT TREATMENT



IFOP STAR REFINERY

Türkiye



AUSTRALIA PACIFIC LNG

Australia



SABINE PASS LNG

USA



CORPUS CHRISTI LNG

USA



MITSUBISHI POWER M701 F4 FUEL GAS SKID



MITSUBISHI POWER FUEL GAS SKID



MITSUBISHI POWER M701 F4 FUEL GAS SKID



GENERAL ELECTRIC A160 SKID



COMBUSTION LINER ASSEMBLY



POWER - COMBUSTION COMPONENTS

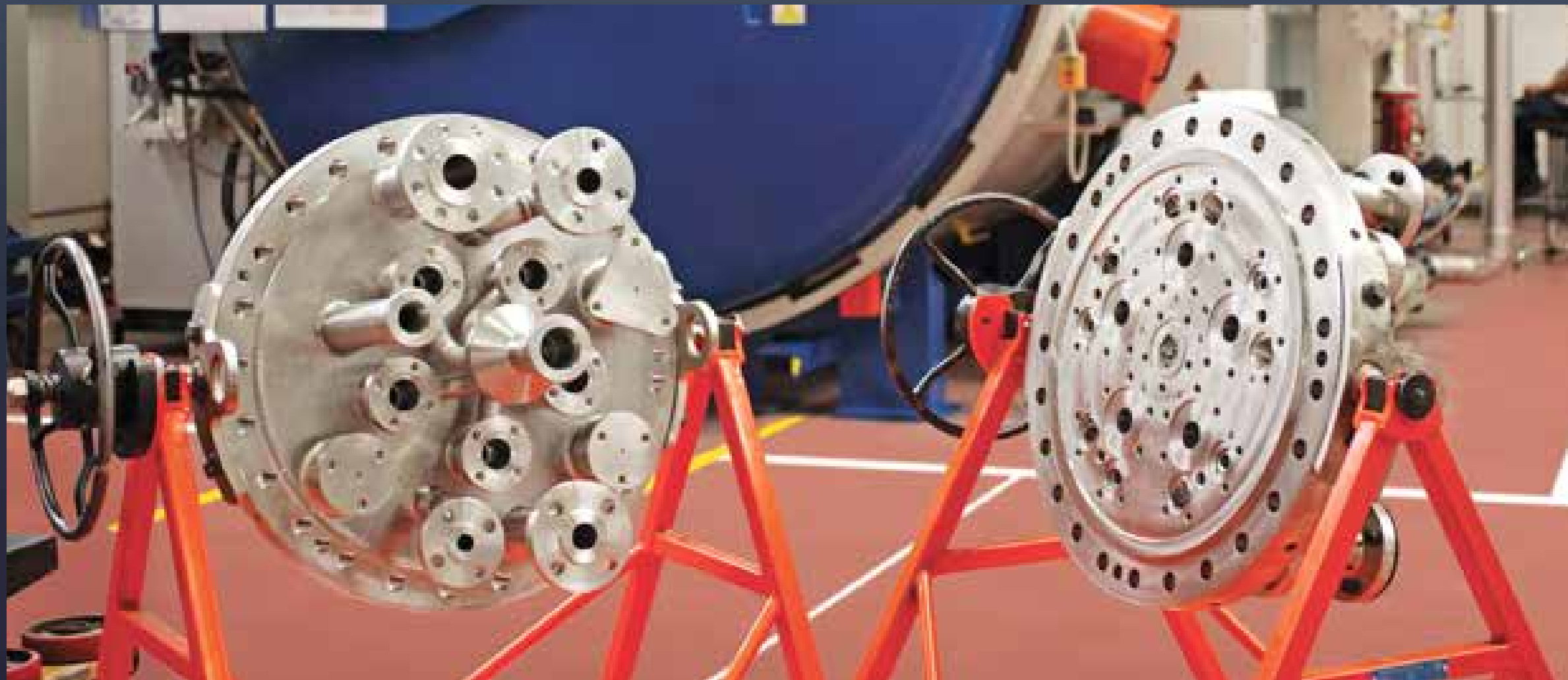

COMBUSTION END COVER ASSEMBLY



COMBUSTION OUTER CAP ASSEMBLY



HIGH PRESSURE ROTATING SEAL - CF 6



HIGH PRESSURE COMPRESSOR CONE - TRENT XWB

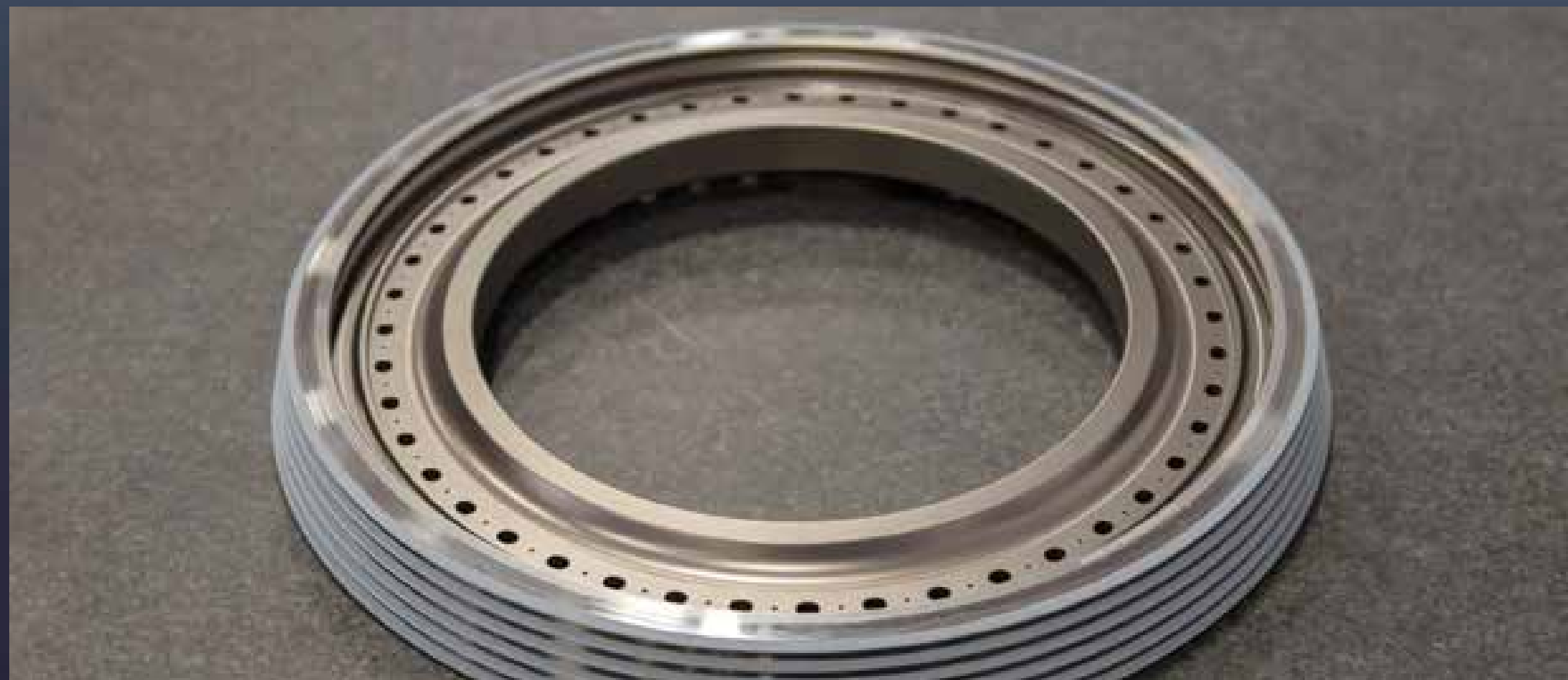

HIGH PRESSURE COMPRESSOR ROTATING SEAL



AIRCRAFT STRUCTURAL COMPONENTS

STRUCTURAL ENGINEERING

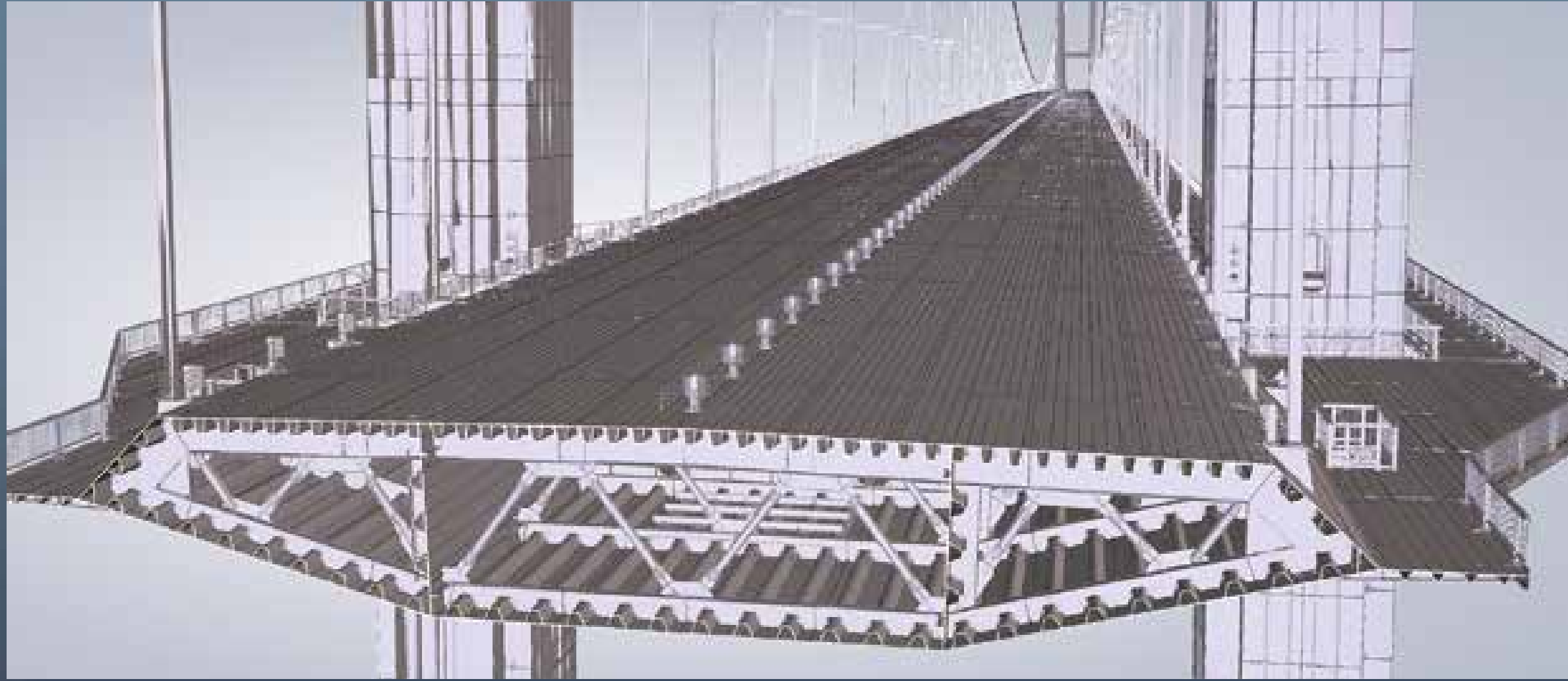

OSMANGAZI SUSPENSION BRIDGE 3D MODEL



1915 ÇANAKKALE SUSPENSION BRIDGE 3D MODEL

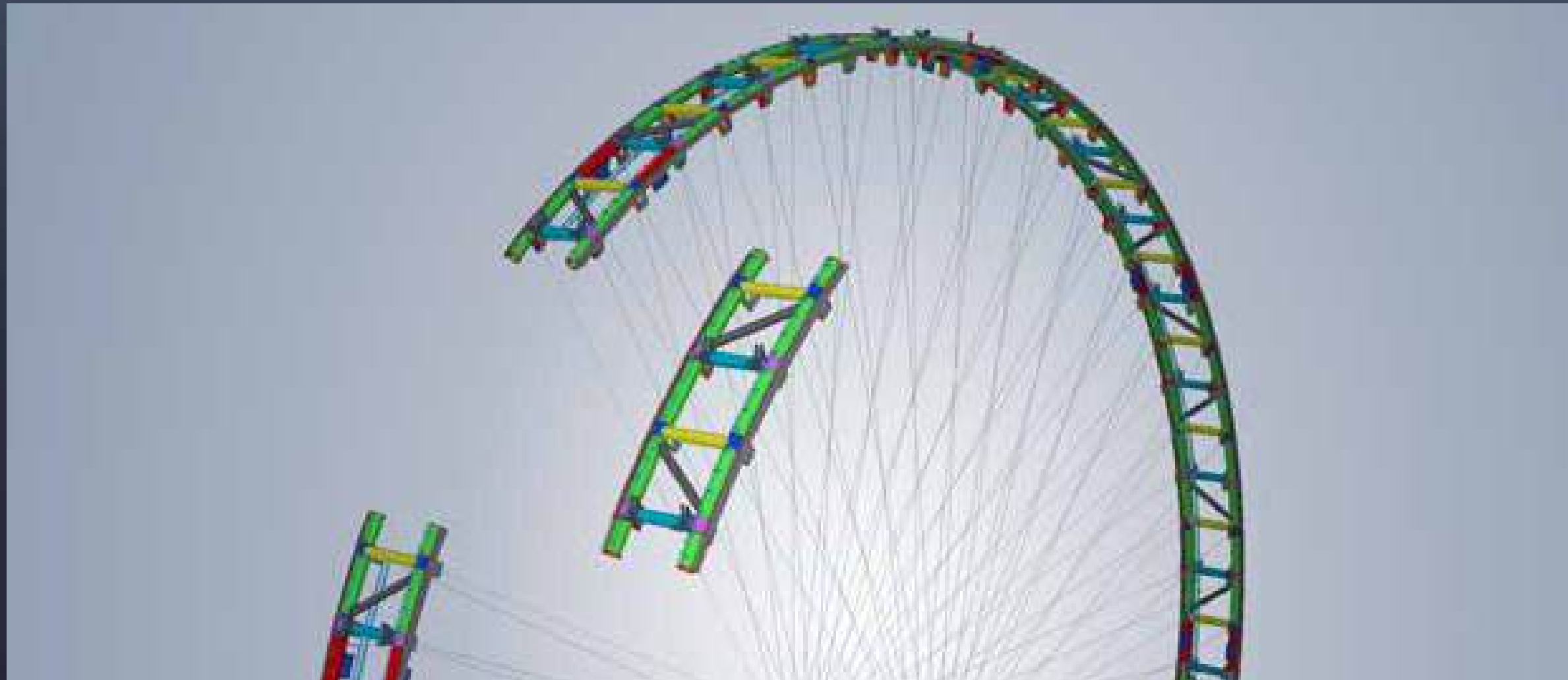

NEW YORK FERRIS WHEEL 3D MODEL



MAKKAH CLOCK TOWER 3D MODEL

PLANT DESIGN & ENGINEERING

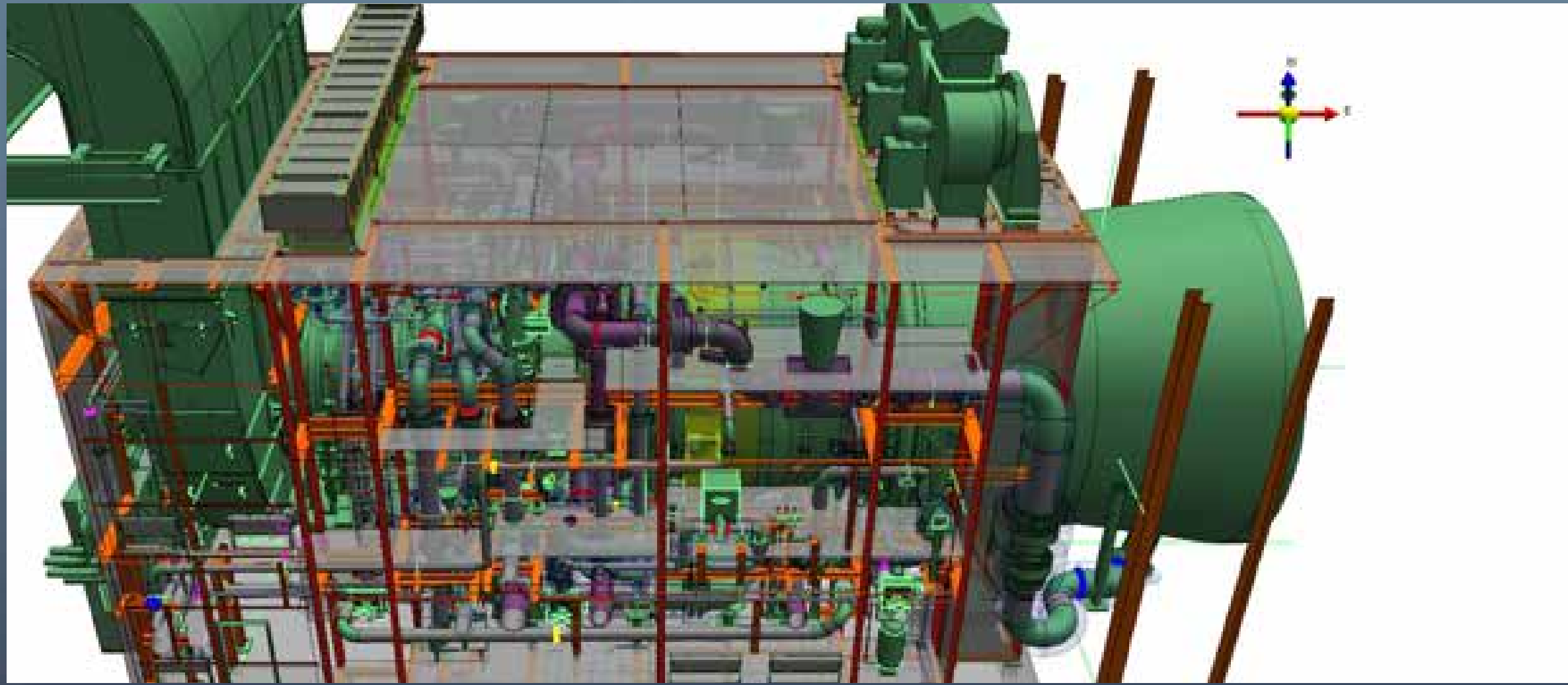

MHI GAS TURBINE MODULAR ENCLOSURE

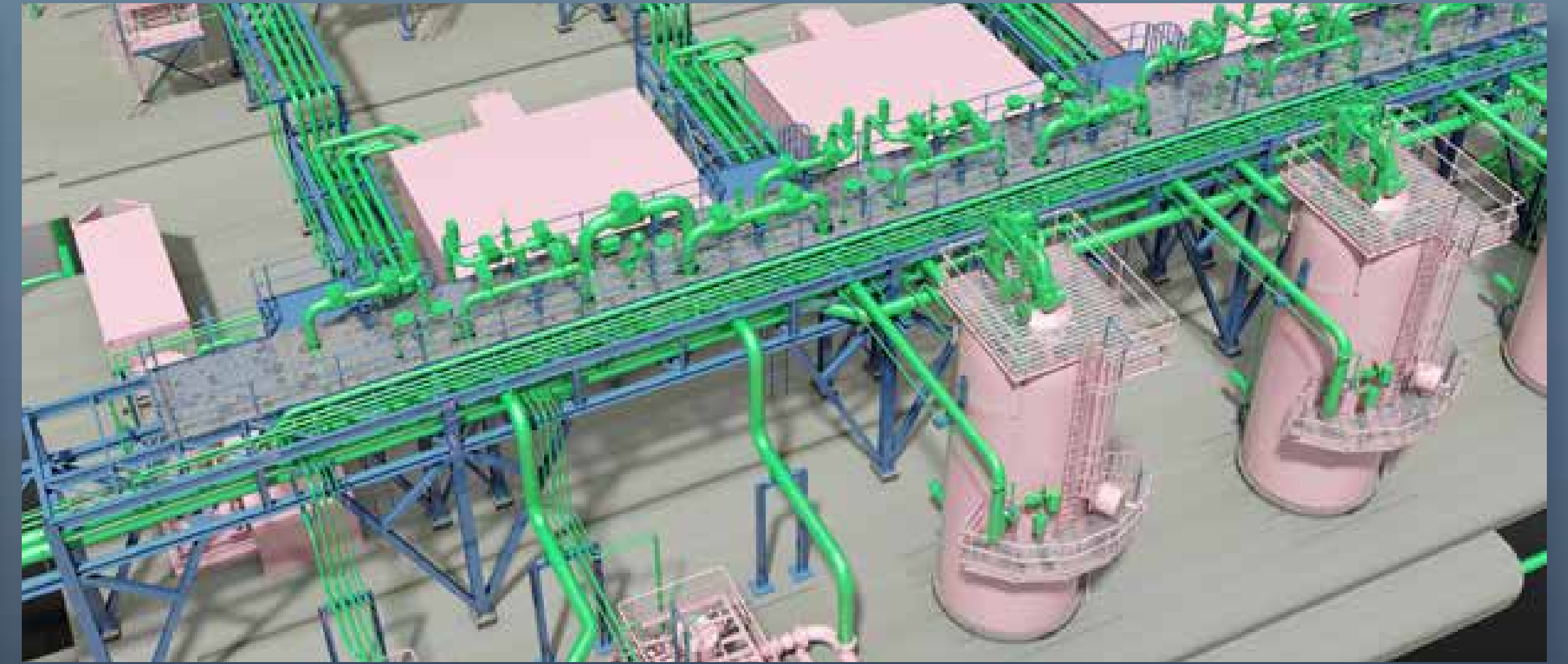

WEST QURNA-2 OILFIELD

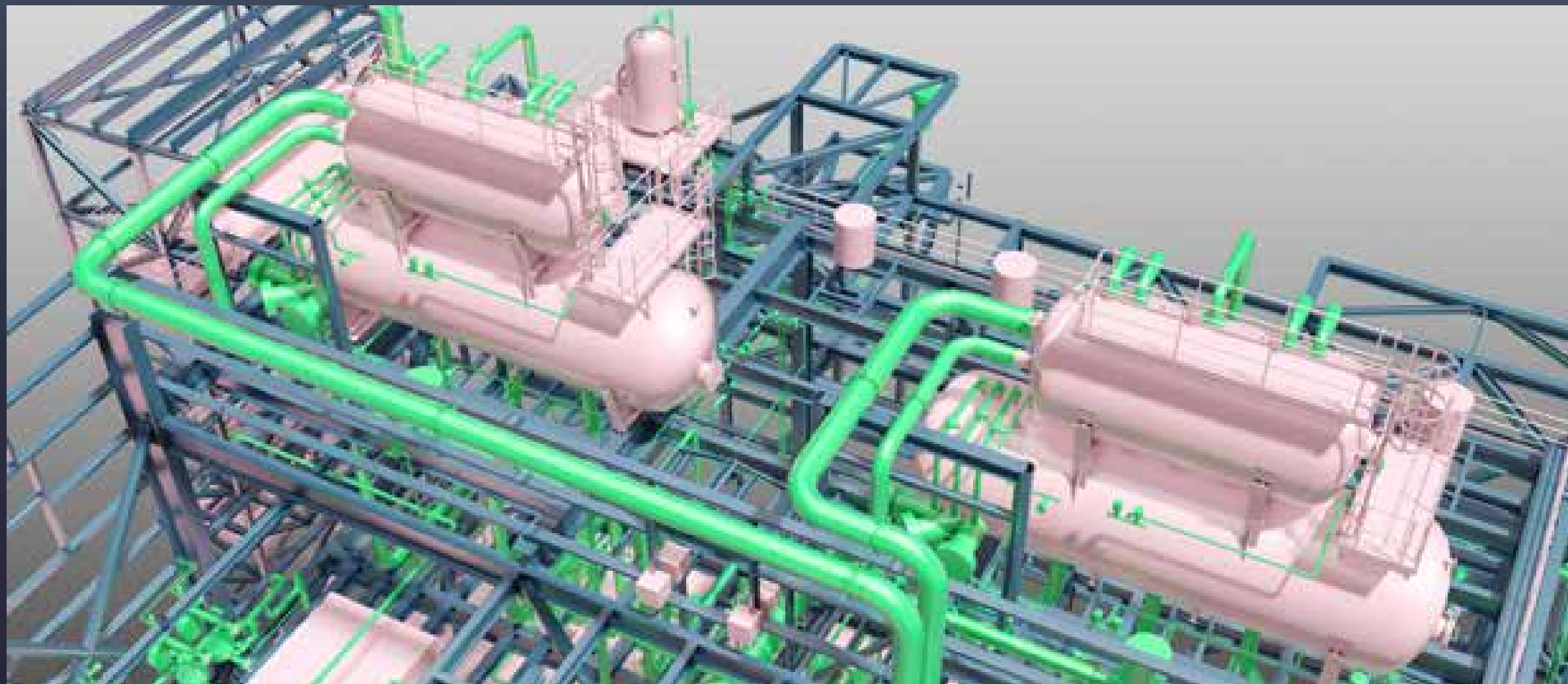

BAZYAN CCPP

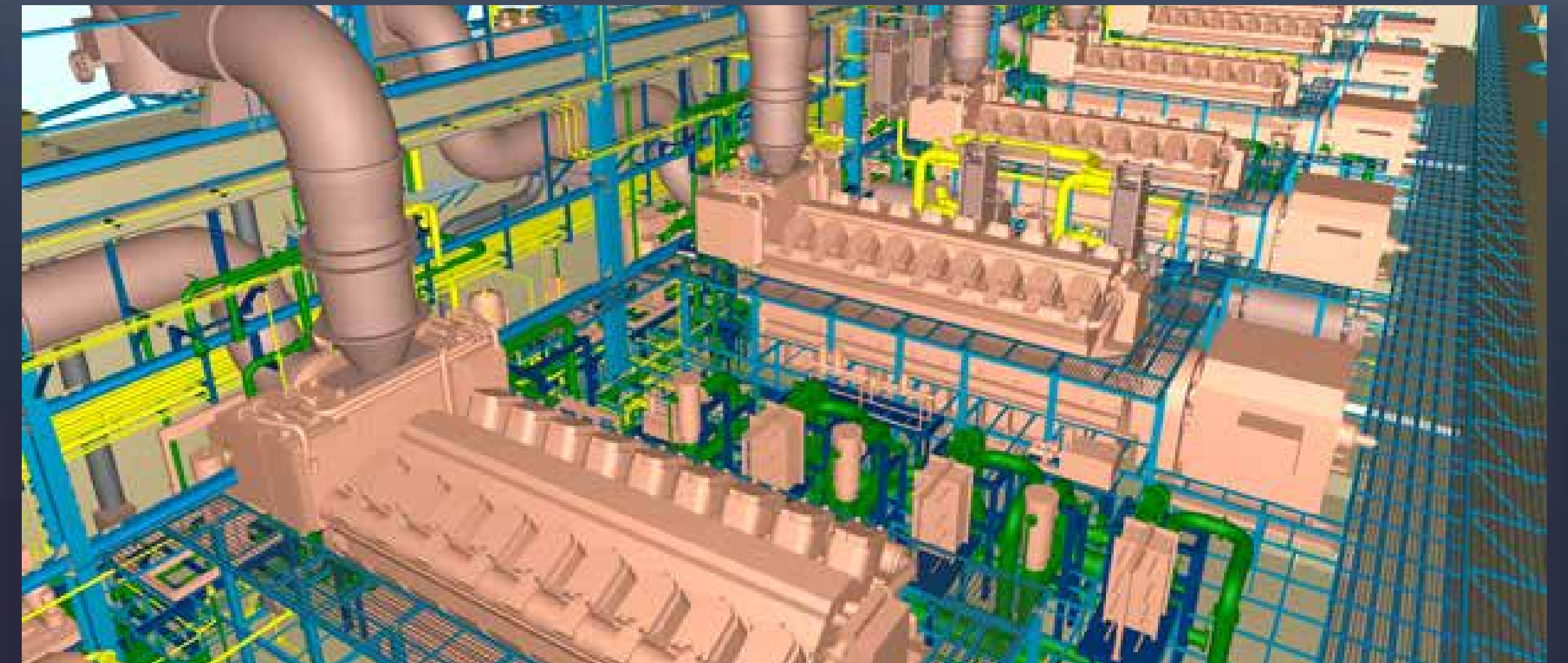

KPS-6 POWERSHIP

FABRICATION & MACHINING



ENERCON ROTOR



ENERCON STATOR



MAMMOET USA



NEW YORK FERRIS WHEEL

CERTIFICATES



FN ISO 3834-2



FN ISO 1090-2

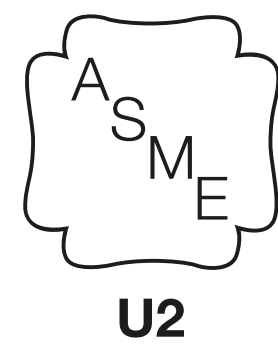
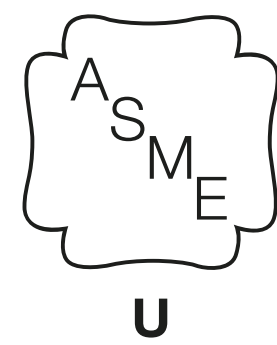
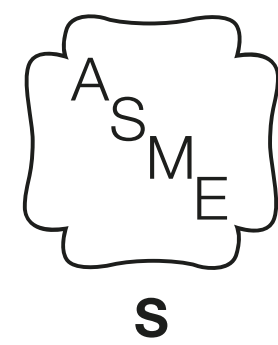
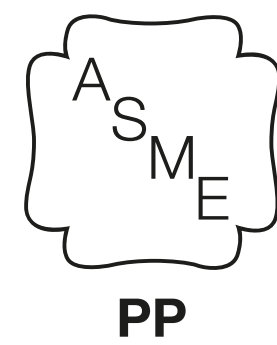
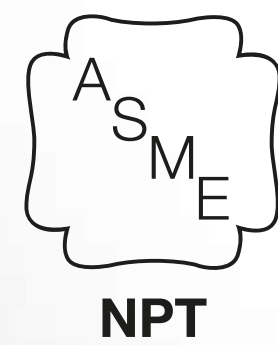
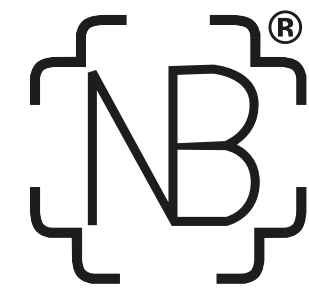

LOGISTICS



OSMANGAZI SUSPENSION BRIDGE



STINGER SECTION PROJECT



TCO FUTURE GROWTH PROJECT



1915 ÇANAKKALE SUSPENSION BRIDGE

LOGISTICS



ÇİMTAŞ SHIPYARD

Gölcük / Türkiye



ÇİMTAŞ STEEL

Gemlik / Türkiye



ÇİMTAŞ PIPE - ÇİMTAŞ MACHINING

Gemlik / Türkiye

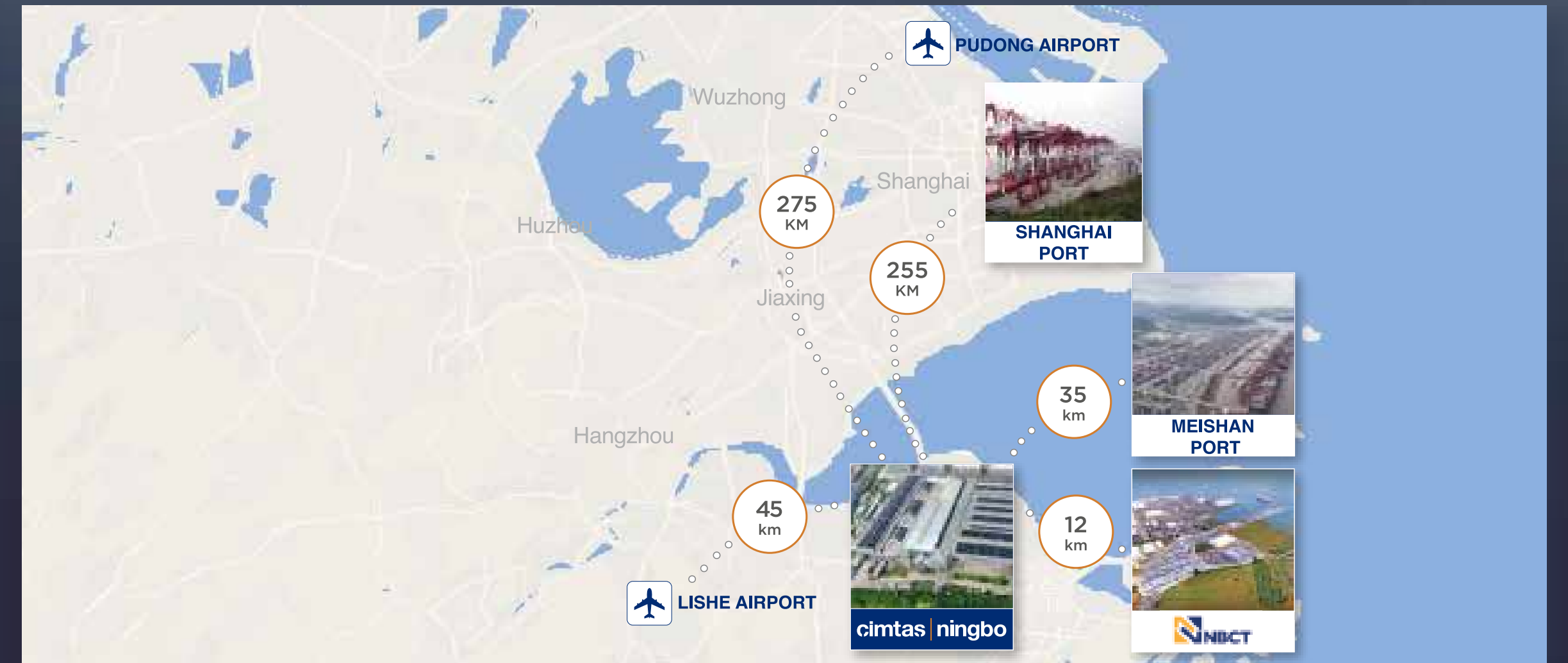

ÇİMTAŞ NINGBO

Ningbo / China

WORLDWIDE PROJECTS

80 COUNTRIES+ORBIT.

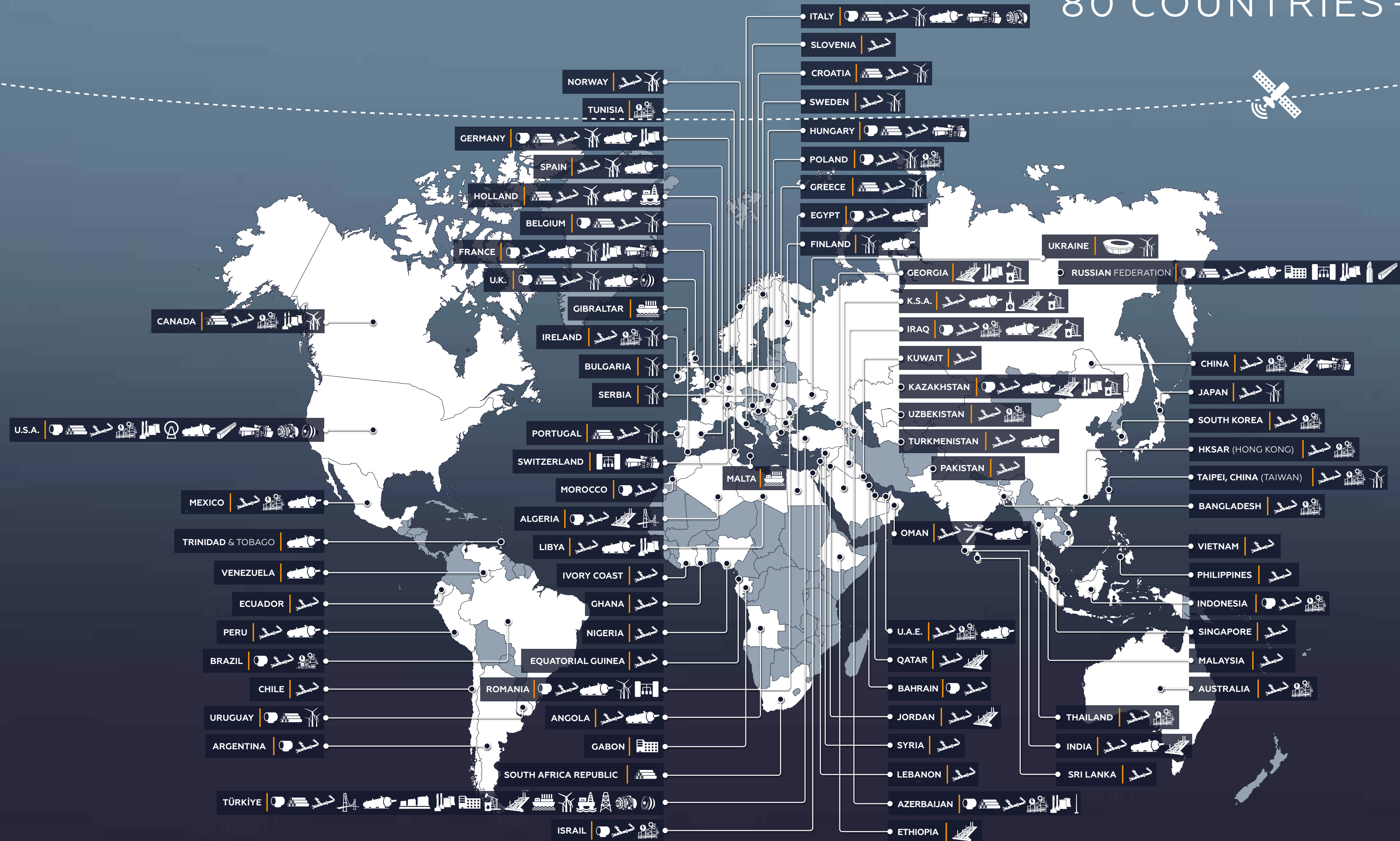

GROUP COMPANIES

PRODUCTS & ABILITIES

cimtas | steel

Gemlik / Türkiye

- STRUCTURAL STEEL
- PRESSURIZED EQUIPMENT
- OFFSHORE STRUCTURE

- STEEL WIND TOWER & COMPONENTS
- MODULARIZATION
- STRUCTURAL ENGINEERING

cimtas | pipe

Gemlik / Türkiye

- SPOOL FABRICATION
- PIPE MANUFACTURING

- FITTING MANUFACTURING
- PLANT ENGINEERING

cimtas | shipyard

Gölcük / Türkiye

- STRUCTURAL STEEL
- OFFSHORE STRUCTURE
- FLOATING STRUCTURE

- SHIPBUILDING
- STEEL WIND TOWER
- XL MODULARIZATION

cimtas | ningbo

Ningbo / China

- SPOOL FABRICATION
- MODULARIZATION

- SKID
- INSTALLATION

cimtas | machining

Gemlik / Türkiye

- 5 AXIS PRECISION MACHINING
- ELECTRON BEAM WELDING
- THERMAL SPRAY COATING

- VACUUM HEAT TREATMENT
- ROBOTIC LASER WELDING & CUTTING
- CHEMICAL PROCESSING

SUSTAINABILITY

Çimtaş, along with the efforts to attain its wide-range social and economic sustainability goals, is striving to reduce its environmental footprint with all solar-powered facilities, paperless processes and responsible water & waste management approach; and by caring for an olive yard with a tree for each of its employees, a special olive kind awarded with protected designation of origin (PDO) status by the European Union at region where Çimtaş's core facilities are located.



THANK YOU
FOR MORE

www.cimtas.com

